

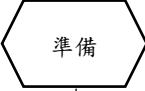
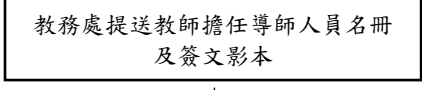
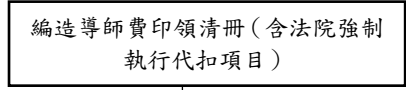
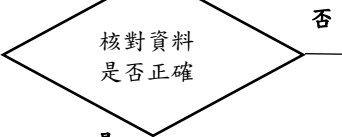
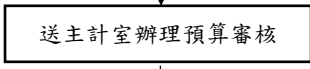
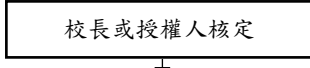
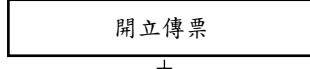
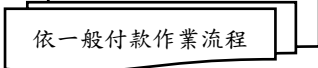
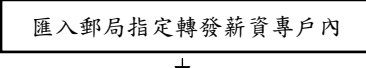
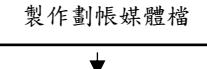
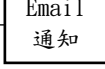
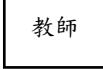
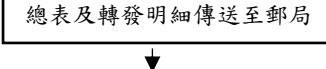
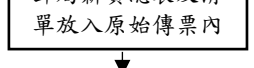
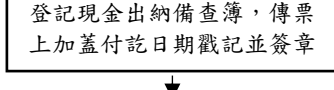
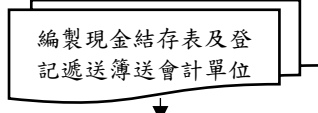
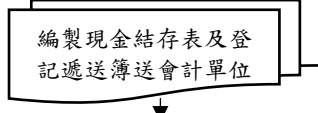

國立臺北商業大學總務處出納組

導師費發放作業流程

權 責	作 業 流 程	執 行 時 間	產 出 表 單
學務處 主計室 校長室		每學期	各學制擔任導師人員名冊
出納組		每月	導師費印領清冊
學務處		每月	
主計室		每月	
校長室		每月	
校長室		每月	支出傳票
主計室		每月	
出納組		每月	
出納組		每月	委託郵局代存員工薪資總總表 郵局轉發清單
出納組		每月	
出納組		每月	
出納組		每月	
郵局		每月	
出納組		每月	
出納組		隨時	
出納組		隨時	現金出納備查簿
出納組		每日	現金結存日報表 傳票遞送單
主計室		每月	現金結存月報表
	